

Different Approaches for the Modelling of High Viscous Dampers in Piping Dynamic Analysis. Acceptable Limits for Simplifications.

Alexey Berkovsky^a, Peter Vasilyev^a and Oleg Kireev^a

^aCKTI – Vibroseism, Saint Petersburg, Russia, e-mail: bam@cvs.spb.su

Keywords: High Viscous Damper, Modelling, Maxwell Model, Dynamic Analysis.

1 ABSTRACT

During recent decades High Viscous Dampers (HVD) have been intensively implemented in Nuclear and Conventional Industry for protection of piping systems and equipment from the wide range of dynamic loads: earthquake, water/steam hammer, operational vibration, etc.

Application of these devices requires from the Designer/Analyst to implement a proper procedure covering all stages of design: selection of damper's location along pipeline, choosing damper's type, and finally modelling of damper in the frame of piping dynamic analysis.

Presented paper addresses namely the last issue: modelling of viscous dampers in piping seismic analysis. It is well-known that High Viscous Damper exhibits essential frequency-dependent characteristic of dynamic stiffness that hardly could be described by the conventional approach available in most commercial piping software programs: representing of damper's action by a spring element active for dynamic loads only. From the other hand more sophisticated 4-parametrical Maxwell model (Kostarev et al, 1993) that allows accurately reproduce damper's characteristics over frequency range of interest is not widely used in the specialized piping software. Besides, application of Maxwell model requires performing of Time History Analysis while the conventional design procedure for seismic calculations is Response Spectrum Method that uses Floor Response Spectra as seismic input.

Paper presents several numerical examples of piping calculations with different models of dampers and discusses acceptability and limits for implementation of a simplified approach when damper is modelled by means of spring elements.

2 INTRODUCTION

Viscoelastic Pipework dampers or with another name of High Viscous Dampers (HVD) have a long and successful story of implementation for seismic upgrading and vibration control of piping systems and components for different installations: NPPs, conventional power plants, industrial facilities. As a dynamic restraint HVD is a device that works in a softer manner than snubbers providing to the system essential additional damping. High damping in the device is a result of deformation of an extremely high viscous liquid that is located in the space between damper's piston and housing, Figure 1.

Significant peculiarity of HVD is nonlinear damping and stiffness characteristics against frequency of excitation. It was shown in a number of works (Kostarev et al, 1993; Berkovsky at al, 1995, Lewandowski at al, 2007) that such dependence could be satisfactory approximated by four-parametrical Maxwell model. For purposes of piping dynamic analysis this model could be easily introduced in a frame of Time History Analysis by means of spring and ideal damper elements connected in line. However the difficulties exist for implementation of such model in the frame of conventional Response Spectrum Method (RSM) that realized in most commercially available piping software and has been still in use as a main design tool for seismic analysis.

So, the intent of this paper is to assess the possibility and acceptable limits for implementation of HVD simplified model by means of spring elements in the frame of conventional RSM, to define accuracy of such

an approach and to develop recommendations for software upgrading for a correct modelling of HVDs, if necessary.

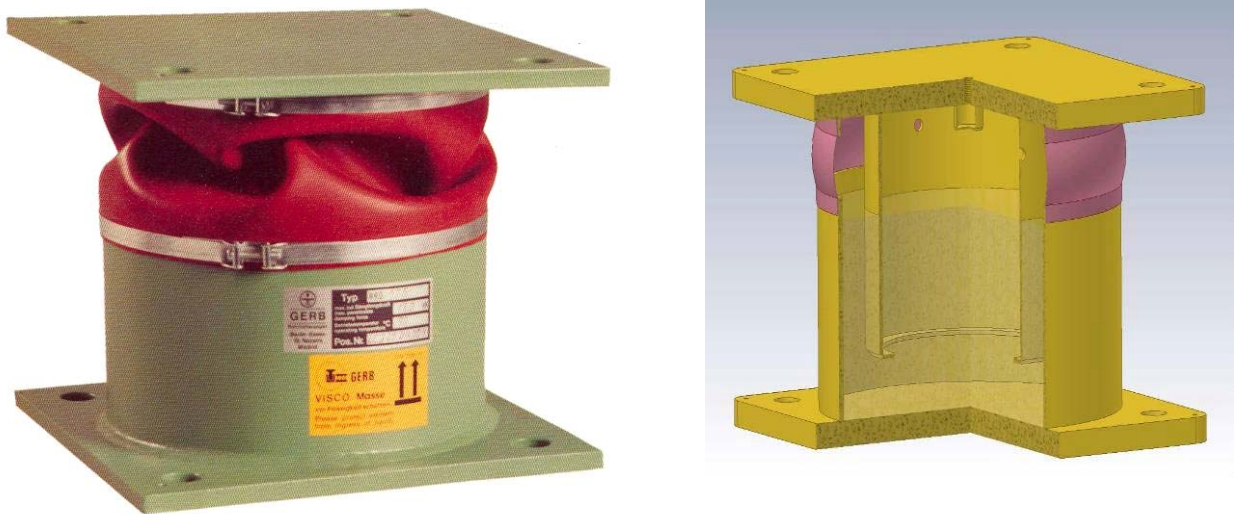

Figure 1. Typical Viscoelastic Pipework Damper: outside view and cross-section (courtesy of GERB Schwingungsisolierungen GmbH & Co. KG, Berlin)

3 MATHEMATICAL MODEL OF HIGH VISCOUS DAMPER

As it follows from the numerous test results and Manufacture Catalogue [GERB] dynamic stiffness of HVD is significantly changed over frequency range, since the damper's dynamic properties are function of working liquid as well as arrangement of damper's internal elements. Working Viscous Liquid used in dampers defines damper's viscous-elastic behaviour. The simplest mathematical model describing such behaviour is a Maxwell Model which consists of connected in line ideal viscous damper and spring element, Figure 2.

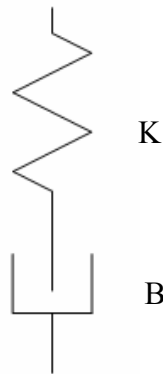

Figure 2. Maxwell Viscous-Elastic Model

Such model demonstrates the following features, which are typical for the measured HVD properties:

- the reaction of HVD at the low frequency loading range is considered as a viscous and may be described by an expression: $R = -B \cdot v$, where R – reaction force, v – velocity of a piston relatively to the housing, B – damping resistance;
- for the high frequency loading range the damper's reaction shows essentially elastic character and may be described as: $R = -K \cdot x$, where x – relative displacement "piston-hosing", K – stiffness ratio.

In case of the Maxwell Model, K is a stiffness of spring element, B – damping coefficient for the ideal viscous element. The parameter named as a *characteristic frequency* of Maxwell model is often used in various applications is $\omega_0 = K/B$.

In case of damper's harmonic loading, when the damper's piston is moved relatively the housing with frequency ω ($x = x_0 \sin(\omega t)$), the damper's reaction force would be harmonic as well, but shifted on the some phase angle: $R = x_0 C_e \sin(\omega t) + x_0 C_v \cos(\omega t)$, where: x_0 – oscillation amplitude, ω - angular frequency of forced oscillations, t – time, C_e – elastic part of damper's dynamic stiffness, C_v – viscous part of damper's dynamic stiffness. Damper's reaction force may also be rewritten in a form:

$$R = x_0 C_s \sin(\omega t + \varphi) \quad (1)$$

where:

$$C_s = (C_e^2 + C_v^2)^{1/2} \quad \text{– equivalent damper's stiffness for a given frequency,}$$

$$\varphi \quad \text{– phase angle (tg}(\varphi) = C_v/C_e).$$

It should be noted that damper's stiffness components are highly dependant on the frequency ω . These dependencies for Maxwell Model have the following form:

$$C_e = K(\omega/\omega_0)^2 / (1 + (\omega/\omega_0)^2) \quad (2)$$

$$C_v = K(\omega/\omega_0) / (1 + (\omega/\omega_0)^2)$$

Graphically they are shown in Figure 3.

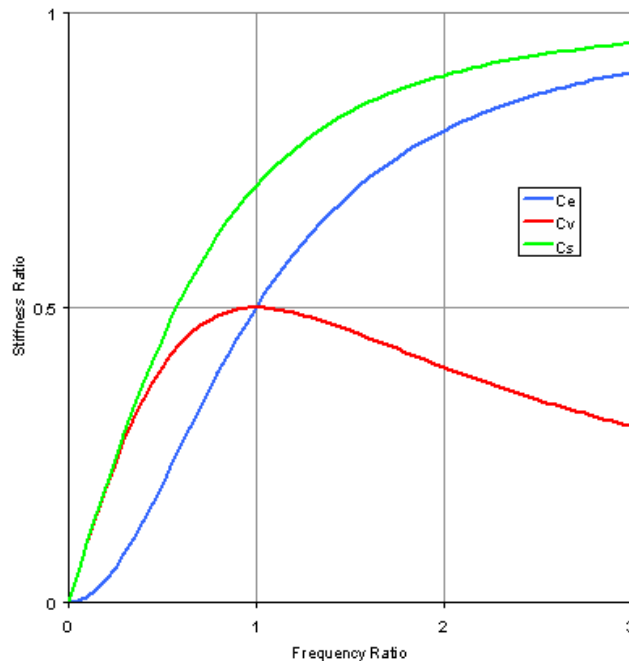

Figure 3. Dependence of Maxwell Model Characteristics from the frequency.

The frequency ratio shown in this plot is ω/ω_0 , stiffness ratio – C/K . When the frequency of vibration achieves the value of characteristic frequency ω_0 elastic and viscous stiffness parts become equal and make one half from the spring stiffness value K . In the frequency range less than ω_0 the viscous part is dominated and contra versa: for the high frequency range the elastic component is prevailed. Change of the phase angle φ depending from the frequency is shown in Figure 4:

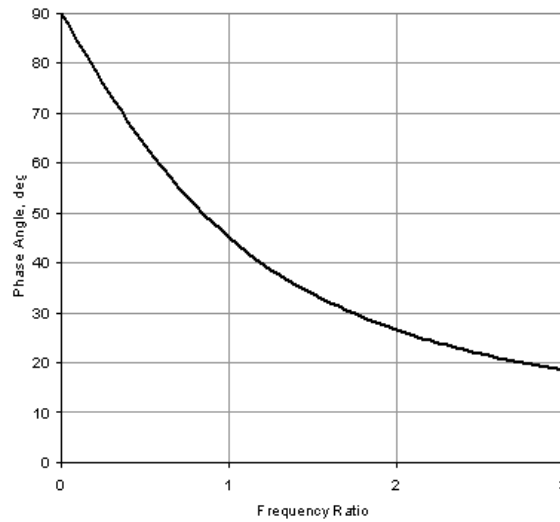

Figure 4. Dependence of HVD phase angle from the frequency ratio.

It should be noted that dynamic characteristics of the real High Viscous Dampers derived from the experiments are more complex than those shown in Figure 3. However, it was recognized that a set of two Maxwell chains demonstrates quite appropriate results for engineering purposes. Such model is presented in Figure 5:

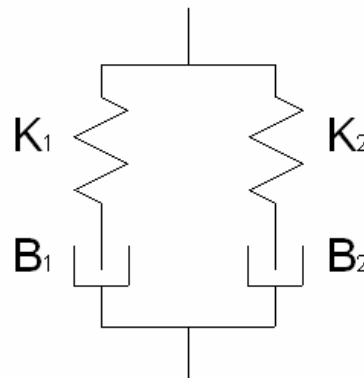

Figure 5. Scheme of the mathematical model of High Viscous Damper.

Under such approach the expressions (2) are transformed to the following form:

$$C_e = K_1 * (\omega / \omega_1)^2 / (1 + (\omega / \omega_1)^2) + K_2 * (\omega / \omega_2)^2 / (1 + (\omega / \omega_2)^2) \quad (3)$$

$$C_v = K_1 * (\omega / \omega_1) / (1 + (\omega / \omega_1)^2) + K_2 * (\omega / \omega_2) / (1 + (\omega / \omega_2)^2)$$

where:

$\omega_1 = K_1 / B_1$ and $\omega_2 = K_2 / B_2$ – characteristic frequencies for first and second Maxwell chains

Thus, the problem of creation of the mathematical model for High Viscous Damper based on the experimental data is reduced to definition of four unknown parameters of model. Lets assume, that N sets of experimental data in form of $\{\omega^i, C_e^i, C_v^i, i=1, 2, \dots, N\}$ are known. Then, the target function can be written down as the sum of squares of residuals between the experimental and «theoretical» values of stiffness components:

$$S = \sum ((C_e^i - C_e(\omega^i))^2 + (C_v^i - C_v(\omega^i))^2) \quad (4)$$

Unknown parameters of model are defined then by finding of minimum of target function by the use of any of optimization methods. It should be noted that the “classical” least-squares method in this case does not work since the model's parameters included in equations are non-linear. The Figure 6 shows an example of experimental data approximation for determining of HVD model characteristics:

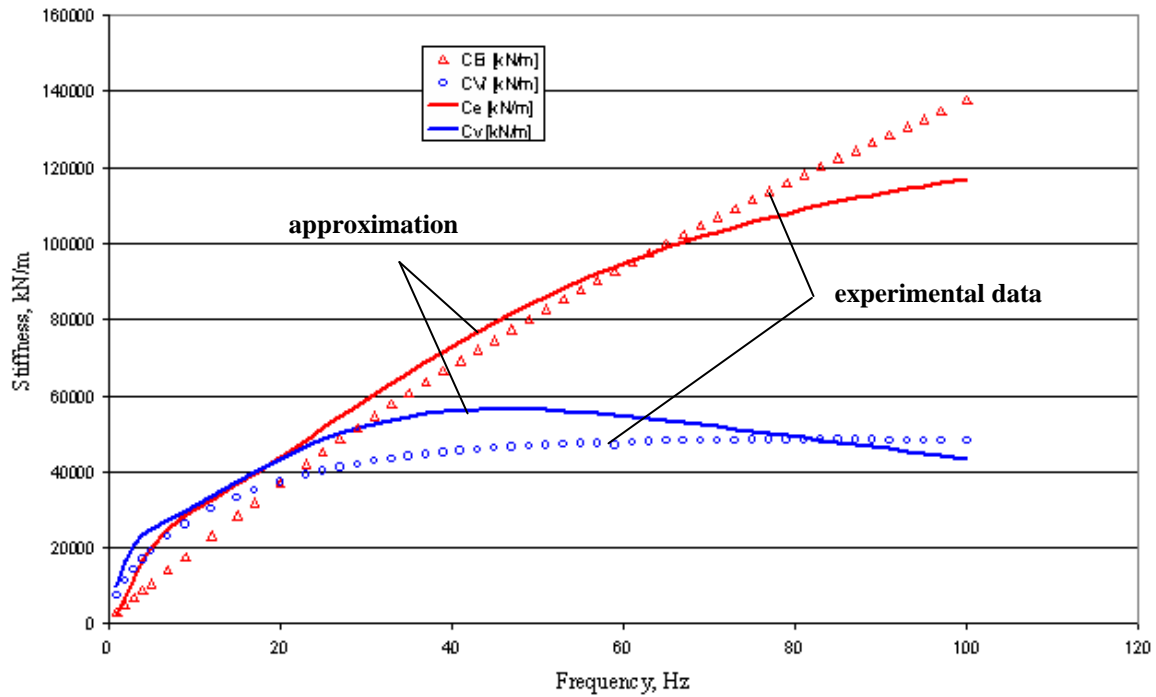

Figure 6. Approximation of the Experimental Data with the use of 4-parameters Maxwell Model of HVD

4 SIMPLIFIED MODEL OF HVD

Described above modeling of HVD by means of 4-parametrical Maxwell model is suitable for realization in the frame of the Time History Analysis (THA). However, for design purposes such method of seismic analysis is used rather rarely. Moreover, Maxwell model of HVD is realized only in a few software packages: ROHR2 (<http://www.rohr2.com/>) and dPIPE (<http://www.dpipe.ru>). Most commercially available piping software packages still use for dynamic restraints only "snubber" model: spring element that does not resist static loads and is active only for a dynamic impact. The benefits of such modeling is a possibility to implement conventional response spectrum (RSM) method for a solution. From the other hand, it is clear that such approach neglects damping introduced by HVD in analyzed piping system that is a core feature of HVDs and positively influences on dynamic capacity of a system.

The following discussion is devoted to results of piping seismic analysis when HVD is modeled by means of "snubber" spring element with equivalent stiffness chosen on the basis of some "character" frequency that defines damper's response under certain excitation. One of such procedures that could be implemented to define equivalent damper's spring ratio is shown in Figure 7. Use of this algorithm involves iterative calculations of piping natural frequencies and mode shapes up to convergence of character frequency for each damper.

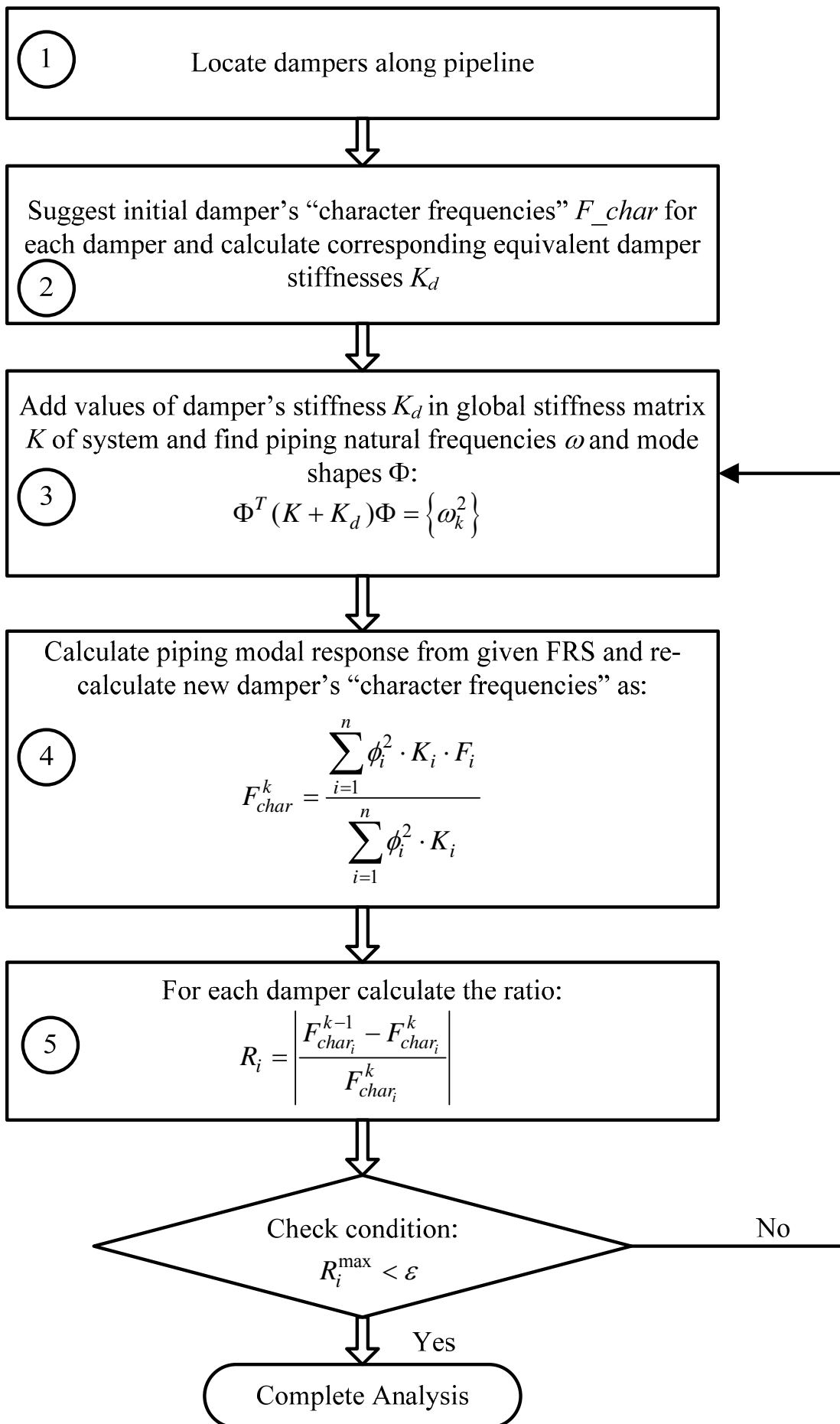

Figure 7. Flow-chart for iterative procedure of selection damper's "character frequency"

To check acceptability of such approach several piping systems from the real applications were taken for numerical evaluation, Figure 8. HVD of different types were installed on considered piping to reduce seismic loads. These systems chosen from the industrial and nuclear piping are different in sizes, layout and modal properties, Table 1. For THA seismic loads applied to analyzed systems were defined in terms of three-component accelerograms. Response spectra corresponded to these accelerograms are also different in shape and frequency content: from the broadened design spectra to rather narrow spectra with sharp peaks on some frequencies.

To investigate difference between two approaches: Maxwell model + THA vs. Spring Model + RSM the following procedure has been implemented:

1. Baseline solution was taken from THA with representation of HVD by means 4-parametrical Maxwell model for each spatial direction. Seismic input was defined in terms of three-component Time History Acceleration.
2. Acceleration Response Spectra used as Seismic input in frame of Response Spectrum Method analysis were generated directly from the given TH acceleration records with a fine frequency step (0.1 Hz) and damping ratio consistent with those used in THA.
3. In the frame of RSM each HVD was modeled by means of three-component spring elements with spring ratio defined according to the procedure described above.
4. For comparison purposes procedure described in the Piping Benchmark Problems (NUREG) was accepted:
 - a. each considered piping model was divided on several segments (from five to nine, depending on piping length);
 - b. comparison of maximum values of each component of pipe displacements and maximum SRSS values of moments has been performed for each segment ;
 - c. reactions of all piping supports were compared as well on the component to component basis.
5. Each compared parameter was expressed as ratio between RSM and THA. Thus, values higher than 1.0 correspond to a level of conservatism of applied method and vice versus: values less than unity indicate degree of non-conservative estimation.
6. For statistical processing of results the following values were plotted: maximum, minimum, mean and mean value minus one sigma (standard deviation). These values were obtained by processing corresponding results for all piping segments of each considered model.

Results of these comparative analyses are presented in the form of stock diagrams in Figures 9 – 11.

Table 1. Description and properties of analyzed piping.

Piping Model	Description	Range of natural frequencies (up to 33 Hz)¹⁾	Number and type of installed HVD
1 (FW)	Conventional Power Plant Feed Water Line DN200 – DN250	43 natural frequencies from 1.15 Hz	3xVD-325/219-7
2 (HPP)	Conventional Power Plant High Pressure and Temperature Steam line (from DN150 – DN400)	142 natural frequencies from 0.64 Hz	14 HVD: from VD-159/76-7 to VD-426/219-15
3 (IS)	Industrial Piping (DN400 – DN800)	58 natural frequencies from 1.94 Hz	7 HVD: from VD-325/219-7 to VD-630/426-15
4 (JND)	Nuclear Safety Related Piping (DN150 – DN300)	93 natural frequencies from 0.85 Hz	3xVD-325/219-7 + 11xVD-426/325-7
5 (KO)	Nuclear Class 1 Piping (Pressurizer system), DN100	40 natural frequencies from 0.75 Hz	1xVD-219/108-7

¹⁾ frequencies are given for unrestrained piping

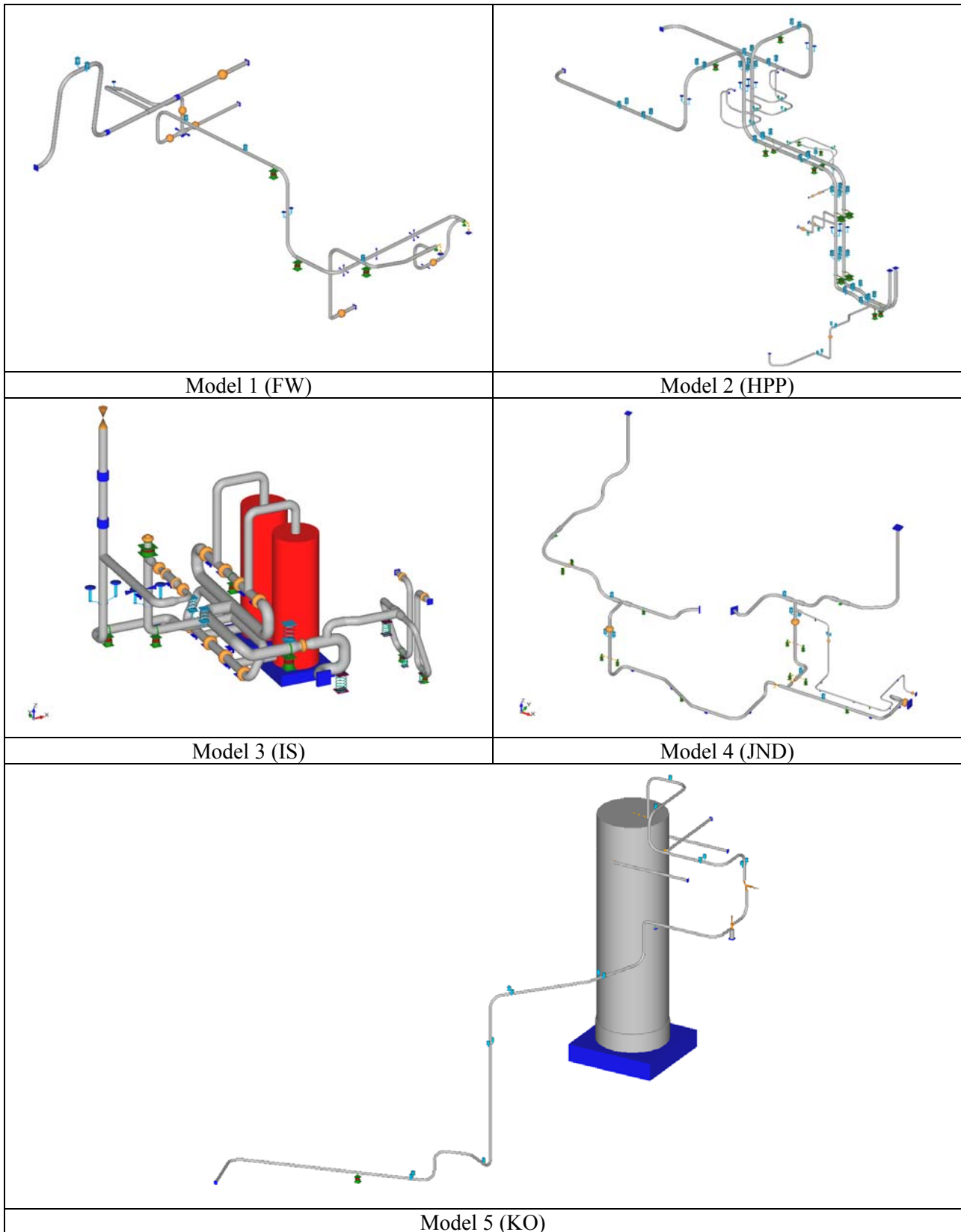

Figure 8. Piping test models.

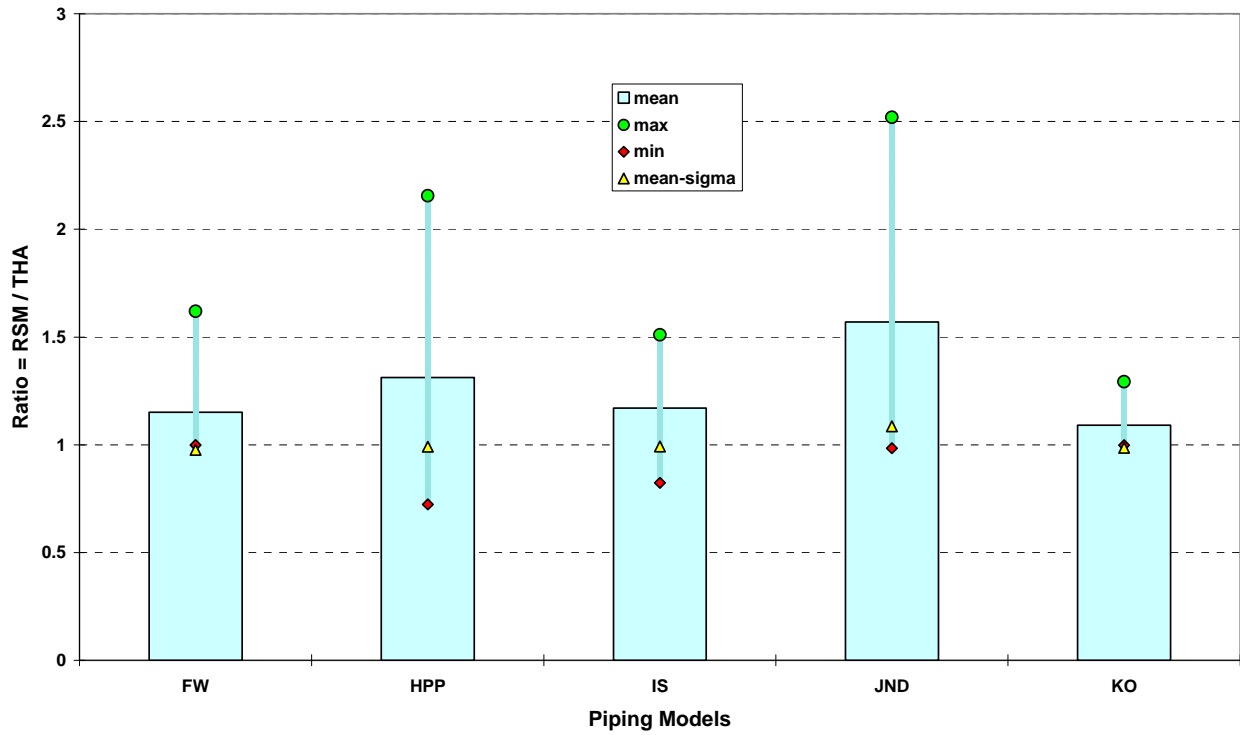

Figure 9. Statistical processing of analysis results. Displacements

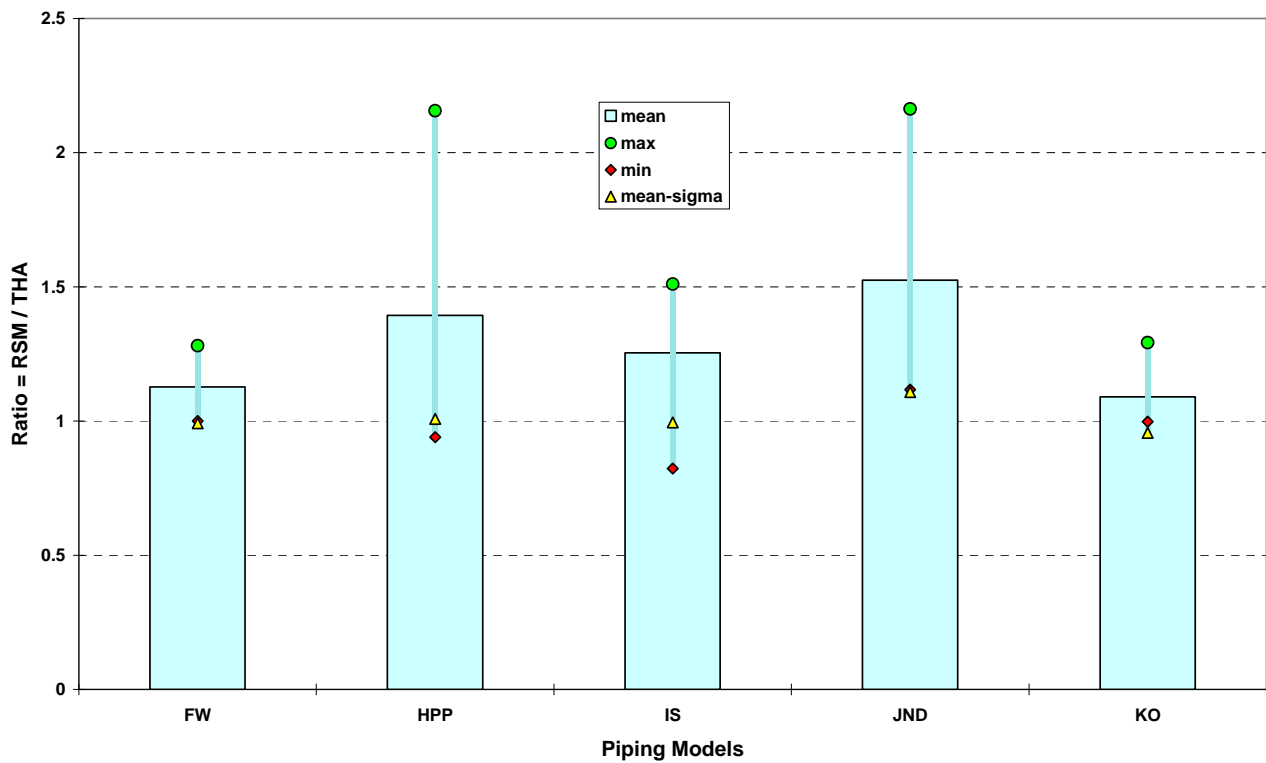

Figure10. Statistical processing of analysis results. Moments.

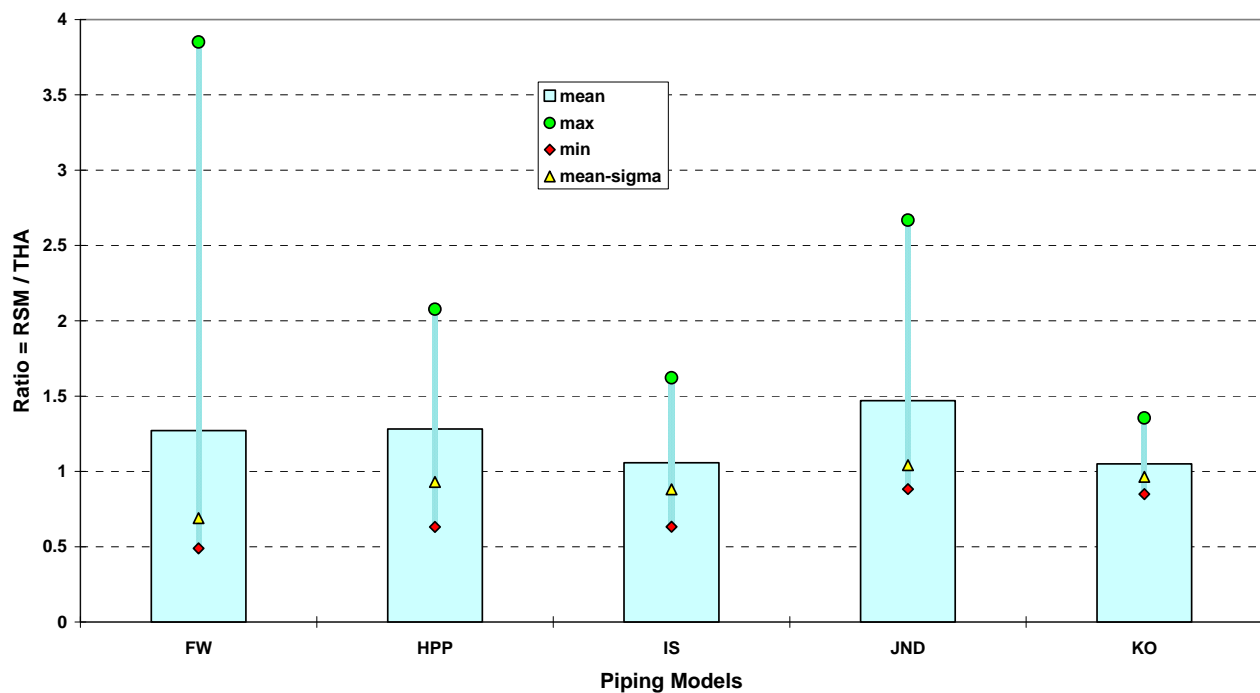

Figure11. Statistical processing of analysis results. Support's reactions

5 CONCLUSIONS

1. According to obtained results the following conclusions can be drawn: a simplified model of HVD generally leads to an overestimation of the seismic response of the system.

The simplified model of HVD provides in general conservatism in calculation of piping system displacements and element's internal moments (stresses).

However, the values of support's reactions in some cases are essentially underestimated, that can not be accepted for the purposes of design.

Thus, it seems that up to now the only one reliable method for seismic design of piping systems equipped with HVD is the Time History Analysis. Nevertheless, the simplified method may be useful on the initial stages of design when it is necessary to locate dampers along pipeline to reduce seismic stresses.

2. It seems that further studies are needed to develop reliable application of the Response Spectrum Method for piping systems with non-proportional damping. For the accurate implementation, such approaches should address several important issues:
 - a. summation rules for mode shapes with high damping ratio (higher than 30 %)
 - b. treating of overdamped modes (damping higher than critical)
 - c. forms of input floor response spectra (evidently that besides conventional acceleration response spectra, response spectra defined in terms of velocity will be needed).
3. Some of existing conventional software for a piping analysis probably will need some upgrading for an accurate modeling of HVDs considering that since 2008 this device is a standard dynamic support according to ASME BVPC Section III Subsection NF (supports).

REFERENCES

- Kostarev V., Berkovsky A., Kireev O., Vasiliev P., Application of Mathematical Model of High Viscoelastic Damper in Dynamic Analysis of NPP Piping and Equipment, SMIRT-12, 1993, paper K20/6
- Berkovsky A., Kostarev V., Schukin A., Vasilyev P., (1995), Seismic Analysis of VVER NPP primary coolant loop with different aseismic devices. Transactions of the 13th SMiRT, Porto Alegre.
- Berkovsky A., Kostarev V., Schukin A., Kostov M., Boiadjiev A., Boiadjiev Z., (1997), Seismic analysis of the safety related piping and PCLS of the WWER-440 NPP. Transactions of the 14th SMiRT, Lyon.
- J. Novotný, J. Novotný jun., Response of the Steam Generator VVER 1000 to a Steam Line Break, Transactions of the 17th SMIRT, Paper # J06-2, Prague, 2003
- Kostarev V., Berkovski A., Schukin A., Upgrading of dynamic reliability and life extension of piping by means of high viscous damper technology. Transactions of PVP ASME Conference, Boston 1999
- NUREG/CR-6049, Piping Benchmark Problems for the General Electric Advanced Boiling Reactor, 1993
- R. Lewandowski, B. Chorążyczewski, Remarks on Modelling of Passive Viscoelastic Dampers, 9th International Conference "Modern Building Materials, Structures and Techniques", Vilnius, 2007
- Pipework Dampers, Technical Report, GERB Schwingungsisolierungen GmbH & Co. KG, 1997